

2017

# Biomimetic pneumatic soft actuator and microfluidic imaging system for analyzing nematodes locomotion

Jikang Qu

*Iowa State University*

Follow this and additional works at: <https://lib.dr.iastate.edu/etd>

 Part of the [Electrical and Electronics Commons](#)

## Recommended Citation

Qu, Jikang, "Biomimetic pneumatic soft actuator and microfluidic imaging system for analyzing nematodes locomotion" (2017).  
*Graduate Theses and Dissertations*. 15610.  
<https://lib.dr.iastate.edu/etd/15610>

This Thesis is brought to you for free and open access by the Iowa State University Capstones, Theses and Dissertations at Iowa State University Digital Repository. It has been accepted for inclusion in Graduate Theses and Dissertations by an authorized administrator of Iowa State University Digital Repository. For more information, please contact [digirep@iastate.edu](mailto:digirep@iastate.edu).

# **Biomimetic pneumatic soft actuator and microfluidic imaging system for analyzing nematodes locomotion**

by

**Jikang Qu**

A thesis submitted to the graduate faculty  
in partial fulfillment of the requirements for the degree of

MASTER OF SCIENCE

Major: Electrical Engineering

Program of Study Committee:

Liang Dong, Major Professor

Wei Hong

Mani Mina

Meng Lu

Iowa State University

Ames, Iowa

2017

Copyright © Jikang Qu, 2017. All rights reserved.

## DEDICATION

This thesis is dedicated to my mother Shuping Xu and my father Jianping Qu for their love.

Thank you for the moral and financial support.

## TABLE OF CONTENTS

	Page
LIST OF FIGURES .....	iv
LIST OF TABLES.....	v
ACKNOWLEDGMENTS .....	vi
ABSTRACT.....	vii
GENERAL INTRODUCTION.....	ix
<b>CHAPTER 1 BIOMIMETIC PNEUMATIC SOFT ACTUATOR</b>	
Abstract.....	1
Introduction.....	2
Design and Fabrication .....	4
Results and Discussion .....	6
Conclusions.....	13
References.....	14
<b>CHAPTER 2 ANALYZING NEMATODES LOCOMOTION</b>	
Abstract.....	16
Introduction.....	17
Design and Fabrication .....	19
Results and Discussion .....	22
Conclusions.....	22
References.....	23
CHAPTER 3 SUMMARY AND CONCLUSIONS .....	24
CHAPTER 4 FUTURE WORK .....	25

## LIST OF FIGURES

	Page
Figure 1.1 Multiple-chamber soft actuator .....	5
Figure 1.2 Applying air pressure in one chamber of the robotic actuator .....	6
Figure 1.3 Applying same air pressure in two chambers of the robotic actuator .....	7
Figure 1.4 Values of air pressure applied in one long chamber of the actuator .....	8
Figure 1.5 Measuring stiffness of the actuator.....	9
Figure 1.6 Applying air pressure in different chambers of the robotic actuator.....	11
Figure 1.7 Applying air pressure in different chambers of the robotic actuator.....	12
Figure 2.1 Schematic of whole siphon-based microfluidic imaging system .....	19
Figure 2.2 Process of siphon-based suction mechanism.....	20
Figure 2.3 Structure of flow-diverting device.....	20
Figure 2.4 Working principle of shadow imaging technique .....	21
Figure 2.5 Shadow imaging system .....	21
Figure 2.6 Nematodes in one channel by using shadow imaging technique .....	22

**LIST OF TABLES**

	Page
Table 1.1 Variable Stiffness of Soft actuator.....	11

## ACKNOWLEDGMENTS

I would like to thank my major professor, Dr. Liang Dong, and my committee members, Dr. Meng Lu, Dr. Mani Mina and Dr. Wei Hong for their support throughout research.

I would like to thank Dr. Erik Andersen, for his training and helping on growing nematodes and making M9 medium.

## ABSTRACT

Hard-bodied robots' operations always are limited because of their rigid structures. Recently, researchers has been inspired by some animals because they can exhibit complex movement with soft structure. Conventional manipulators operate difficultly because of their rigid links in some highly congested environments. They design soft robots, to replace traditional robots with rigid links. With a soft structure and large degrees of freedom, these robots can be used for tasks in highly congested environments. The elephant trunk is one of the most used models due to its high flexibility. Its shape can be changed when pressurized by air. Our study focuses on designing and fabricating a pneumatic soft actuator inspired by elephant trunk, and testing pneumatic actuations with a focus on achieving its multiple freedom of degree movement. Normally, Soft robots are always actuated by variable length tendons embedded in the soft segment. Compared to the traditional approach, pneumatic actuation does not damage the actuator because no more complex components need to be fabricated in the actuator.

Studying small model organisms such as *Caenorhabditis elegans* provides great opportunities for securing diseases in humans. *C. elegans* is easily grown in the laboratory, with maintained in agar-filled petri dishes. These small model organisms also have huge potential for use in drug delivery and image-based screening. There are many developments in microfluidic technologies for imaging small model organisms. Due to severe constraints of volume, Shadow-imaging is one of methods that can record the locomotion of nematodes. The microfluidic device is put on the top of the the camera chip, and the light source is put on the top of the device. Our study focuses on designing a microfluidic device to facilitate high-throughput, imaging-based screening of microscopic nematodes. It involves fabricating microfluidic device, designing and



integrating siphon-based suction mechanism with multiple channels, and using the raspberry-pi camera to record the movement of nematodes in channels.

## GENERAL INTRODUCTION

### Bioinspired Soft Robotics

In nature environment, animals use their soft structure to move effectively. Researchers are inspired by these capabilities soft lithography technologies are implemented into their designs [1]. The purpose is to make soft robots with bio-inspired capabilities that allow flexible movement in congested environments. Human-made robots are mainly designed to be in order to perform precise tasks. Normal actuators are composed of rigid electromagnetic components or some internal engines made of steel and aluminum alloys [2]. By contrast, the majority of animals are soft bodied, and even animals with stiff skeletons are almost entirely soft. Besides, some parts of animal bodies that play important roles in locomotion are highly deformable either.

Studying how animals use their soft bodies to move in complex environments can provide important assistances for using robotic applications in medicine, rescue, and human assistance [3]. Those situations require robots to deal with unexpected movement with unstructured environments or humans. Soft robotics aims to build robots for the unpredictable needs of such situations by stimulating them with their capabilities that are based in material properties. Its purpose is to achieve better mechanisms by stimulating the mechanical intelligence of soft materials either.

Soft materials are essential and important to the mechanical design of animals. They provide many advantages in order to help animals move in highly congested environments [4]. They distribute stress over a large volume, and increase contact time in order to reduce the inner forces. For example, Animals enter into small areas for hunting relying on their highly flexible structures [5]. However, soft structures have limitations. Soft animals needs to be small since it is difficult for them to support their own body weight. All of the extremely large soft animals are

found in water, because their bodies are supported by surrounding medium. Similar limitations apply to soft robots because it is necessary to select materials to match size functionally. Additionally, the high deformability properties of soft tissues limit speed of movement [6].

One of the biggest challenges in soft robotics is designing suitable actuation systems to achieve the functionality of muscles in the animal body. The ability of soft animals changing their body shape depends on a large amount of muscles being distributed over the body. Three actuation techniques are now widely used. The first technique is to use dielectric elastomeric actuators (DEAs) made of soft materials that actuate through electrostatic forces [7]. This technique has limitations. Using DEAs requires a rigid frame that fixes the elastomer normally. A few designs work without rigid components, but they yield low stress, and their fabrication process is very complex. The second technique is to use shape memory alloys (SMAs) [8]. Researchers create coils from a thin wire to amplify the strain. It allows SMAs to be formed into highly flexible springs that can be integrated into a soft structure. However, temperature change affects force generation in SMAs. Overheating might easily damage the actuator permanently. The third technique is to use compressed air and pressurized fluids [9]. Compressed air and fluid can deform soft body directly using channels in elastomers to inflate chambers and create movement in robots.

### **Microfluidic Imaging System for the analysis of behavior in *C. elegans***

*Caenorhabditis elegans* have been used as an experimental tool because of its short life span [10]. With a small and flexible body, it is hard to manipulate *C. elegans*. *C. elegans* lives in the soil and feeds on bacteria.

Microfluidic technology has been used to manipulate *C. elegans* recently. Some unique advantages of microfluidic technology help make good applications in *C. elegans* [11]. First, microfabrication techniques are cheap and simple because soft lithography technology are invented by dedicated researchers. Second, polydimethylsiloxane is a kind of transparent material, which allows transmission of light. Lastly, microfluidic techniques can help manipulate small amounts of liquid and provide fast analysis of small size *C. elegans* [12].

In order to get information from samples, imaging techniques are significant in microfluidics [13]. Microscopes achieve taking images in microfluidic devices conventionally. Recently, researchers have been developed many imaging techniques to find a good solution [14]. Shadow imaging is a better method to take images of samples properly. The sample is put above a camera chip and its shadow is observed directly by camera. The imaging system including shadow imaging technique is not complex but the image resolution is not good enough sometimes. To consider about this issue, the resolution depends on the distance between the sample and the camera, and the pixel size of the camera that researchers use.

## References

1. Kim, Sangbae, Cecilia Laschi, and Barry Trimmer. "Soft robotics: a bioinspired evolution in robotics." *Trends in biotechnology* 31.5 (2013): 287-294.
2. Mavroidis, Constantinos, Charles Pfeiffer, and Michael Mosley. "5.1 conventional actuators, shape memory alloys, and electrorheological fluids." *Automation, miniature robotics, and sensors for nondestructive testing and evaluation* 4 (2000): 189.
3. Murphy, Robin R., Satoshi Tadokoro, and Alexander Kleiner. "Disaster robotics." *Springer Handbook of Robotics*. Springer International Publishing, 2016. 1577-1604.
4. Pfeifer, Rolf, Max Lungarella, and Fumiya Iida. "Self-organization, embodiment, and biologically inspired robotics." *science* 318.5853 (2007): 1088-1093.
5. Cheney, Nick, Josh Bongard, and Hod Lipson. "Evolving soft robots in tight spaces." *Proceedings of the 2015 annual conference on Genetic and Evolutionary Computation*. ACM, 2015.
6. Jayaram, Kaushik, and Robert J. Full. "Cockroaches traverse crevices, crawl rapidly in confined spaces, and inspire a soft, legged robot." *Proceedings of the National Academy of Sciences* 113.8 (2016): E950-E957.
7. Plante, Jean-Sébastien, and Steven Dubowsky. "Large-scale failure modes of dielectric elastomer actuators." *International journal of solids and structures* 43.25 (2006): 7727-7751.
8. Otsuka, Kazuhiro, and Xiaobing Ren. "Recent developments in the research of shape memory alloys." *Intermetallics* 7.5 (1999): 511-528.
9. Ilievski, Filip, et al. "Soft robotics for chemists." *Angewandte Chemie* 123.8 (2011): 1930-1935.
10. Lange, Dirk, et al. "A microfluidic shadow imaging system for the study of the nematode *Caenorhabditis elegans* in space." *Sensors and Actuators B: Chemical* 107.2 (2005): 904-914.
11. Ben-Yakar, Adela, Nikos Chronis, and Hang Lu. "Microfluidics for the analysis of behavior, nerve regeneration, and neural cell biology in *C. elegans*." *Current opinion in neurobiology* 19.5 (2009): 561-567.
12. Breslauer, David N., Philip J. Lee, and Luke P. Lee. "Microfluidics-based systems biology." *Molecular Biosystems* 2.2 (2006): 97-112.
13. Wu, Jigang, Guoan Zheng, and Lap Man Lee. "Optical imaging techniques in microfluidics and their applications." *Lab on a Chip* 12.19 (2012): 3566-3575.
14. Zhu, Hongying, et al. "Optical imaging techniques for point-of-care diagnostics." *Lab on a Chip* 13.1 (2013): 51-67.

## CHAPTER 1. BIOMIMETIC MULTIPLE-CHAMBER PNEUMATIC SOFT ACTUATOR WITH VARIABLE STIFFNESS

### Abstract

This paper reports on a biological inspired pneumatic soft actuator using highly stretchable elastomer. Six air chambers are embedded in the actuator with each three controlling bending and rotating for one segment. This provides a joint motion for the actuator. Pneumatic pumping increases the mechanical stiffness of the actuator. Our studies include designing and testing pneumatic actuations with a focus on achieving its multiple freedom of degree movement.

**Keywords:** pneumatic actuation, bending mode, elephant trunk, stiffness

## Introduction

Traditional hard-bodied robots are used widely in industry. They can be specifically built to complete tasks that require rapid movement, and precise actions. Because they are built of rigid components, it is unsafe if they are used for interaction with human beings. Soft robots provide an opportunity to interact between robots and humans. Human-friendly materials such as Ecoflex and PDMS are often used to build soft robots. On the other hand, soft robots are able to bend with large angular movement and thus can be used in highly congested spaces [1,2]. Hard-bodied robots are often costly, heavy and difficult to control [3,4]. However, hard-bodied robots designed to be lightweight are easy to be damaged by impact or compression. Their joints are especially vulnerable to collisions and bending, since small deformations can make their components position wrongly [5,6].

Soft robots can be deformed continuously and achieve complex motions that emulate biology [7]. Recently, biological inspired soft robots are mainly designed to involve in manipulating objects [8], moving on rough terrain like underwater [9] and medical applications such as soft orthotics for ankle rehabilitation [10] and soft sensing suits for lower-limb measurement [11]. Researchers developed a lot of structures for soft robots based on most flexible animals like caterpillar [12], squids [13] and octopus [14] that own soft bodies. Compared to hard-bodied robots, materials of soft robots are often lighter and less expensive. Besides, because they are fabricated from elastomers, they can provide more complex joint motions. However, they resist damage such as bending) better than hard links.

There are usually two ways to actuate soft robots: variable length tendons such as shape-memory alloy (SMAs) actuators [16] or tension cables [15], for example, robotic octopus arms [16]; or using pneumatic actuation to inflate channels to make it deform continuously. One problem with current soft robots is that how soft an actuator needs to be in order to meet its true potential. Instead of setting the stiffness of robots by changing their materials, another method is to control soft robots' stiffness. For example, one traditional way is embedding soft robots with stiffer materials such as metal [17] or wax [18]. Embedded heaters can adjust robots' stiffness because metal or wax can be thermally softened. However, heating stiffer materials may damage the soft actuator together and positioning embedded heaters properly is also a problem if the actuator is very small. Pneumatic actuation has been used to inflate chambers and the actuator can be stiffer. Compared to the traditional approach, pneumatic actuation does not damage the actuator and the operation is simple because no more complex components need to be added in the actuator.

Recently, Dr. C. Lekkakou studied the design and testing of skins and sleeves for soft robotics. They focus on the mechanical design of the microstructure of those skins inspired from some animals with soft bodies [19]. Our paper aim at designing and fabricating a soft pneumatic actuator with multiple chambers which can perform more complex joint motions. The material of soft actuator is a highly elastomeric siloxane (Ecoflex). We tested the stiffness of the actuator under different applied air pressure and showed how the actuator achieve various bending modes with an improved stiffness under pneumatic actuation.



## Design and Fabrication

This report shows the development of a six-chamber robotic actuator which resembles an elephant trunk that has two segments. Figure 1.1(c) displays a soft cylindrical actuator inspired from the elephant trunk with six pneumatic chambers, which can offer multiple bending modes. The actuator is comprised of two segments which includes one six-chamber segment and one three-chamber segment. The six-chamber soft actuator inspired from elephant trunk is able to bend when air pressure is applied to the chamber (Figure 1.2). Since the material is highly elastomeric, air pressure impacts on the inner wall of the chamber. The inner space of the chamber will expand and the actuator would bend by some angles which like an elephant trunk does. The mold of making a three-chamber actuator or a six-chamber actuator is shown in Figure 1.1(a). The only differences are the number and the length of chambers. All components include one large hollow tube, a number tubes and one base. Long chambers are 5 cm long which is as twice as short chambers. The diameter of chambers' bottom surface is 1.6 mm. Figure 1.1(d) shows the whole process of developing a six-chamber soft actuator.

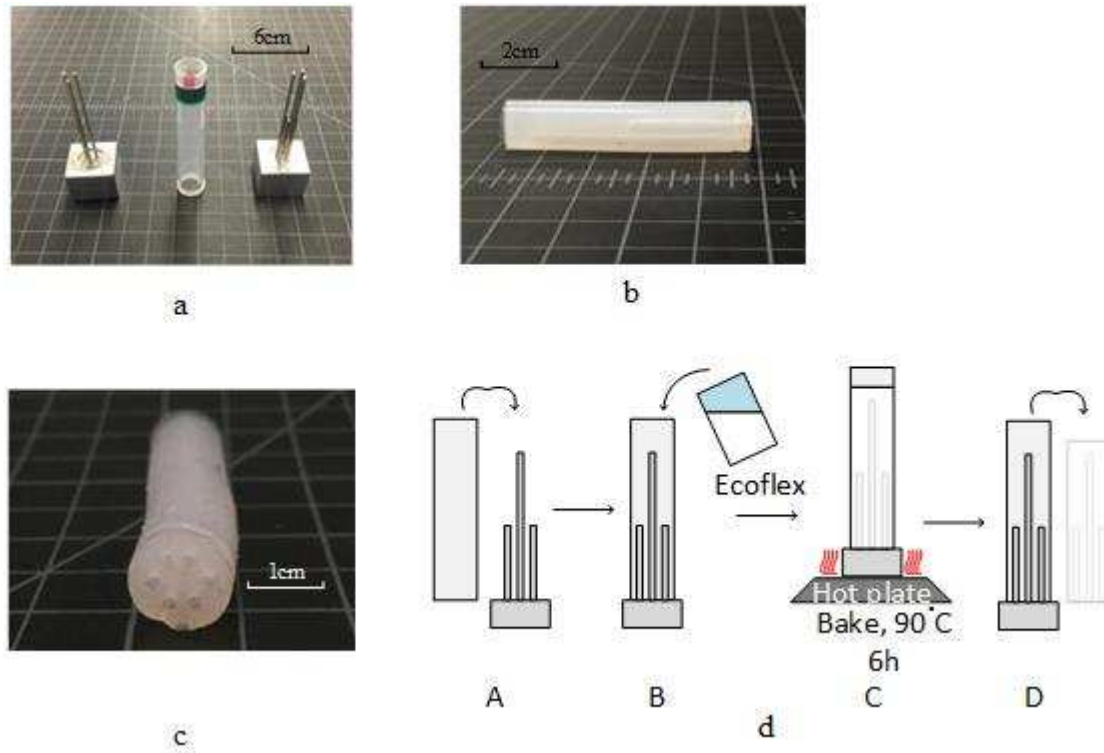

**Figure 1.1.** (a) The mold of making the three-chamber robotic actuator and six-chamber robotic actuator; (b) side view of the six-chamber robotic actuator; (c) bottom view of the six-chamber robotic actuator; (d) basic process of fabrication of the six-chamber robotic actuator

## Results and Discussions

The six-chamber soft actuator can provide in-plane bending under applied air pressure. Figure 1.2 shows the effects of the six-chamber soft actuator after being driven by different air pressure applied in one long chamber. Bending by more than 90 degree is achieved easily and the actuator seems stiffer under higher applied air pressure [Figure 1.2(e), Figure 1.2(f)]. The actuator can bend by larger angle with a small increase of applied air pressure because of high deformability of the material (Figure 1.4). Besides, applying a same air pressure in two long chambers can achieve in-plane bending with higher mechanical stiffness (Figure 1.3).

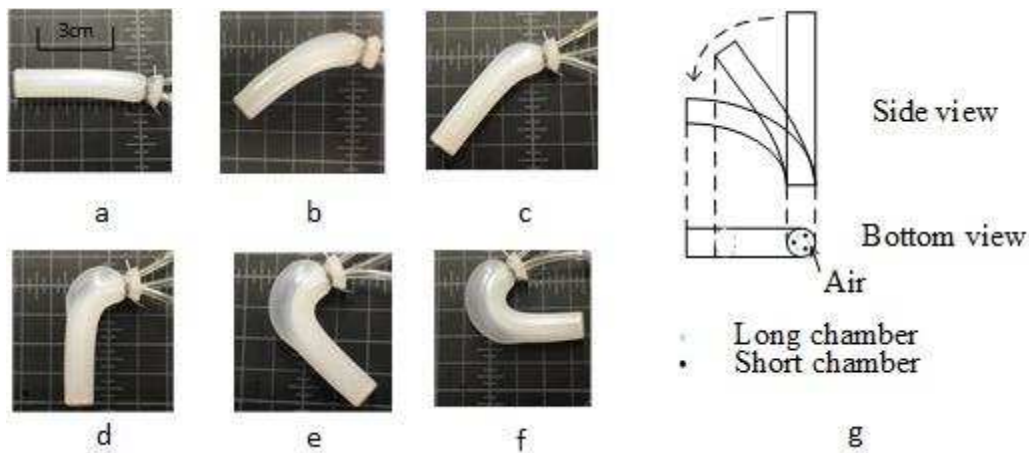

**Figure 1.2.** (a)-(f): The process of applying air pressure in one chamber of six-chamber robotic actuator; (g) schematic of applying air pressure in one chamber of six-chamber robotic actuator

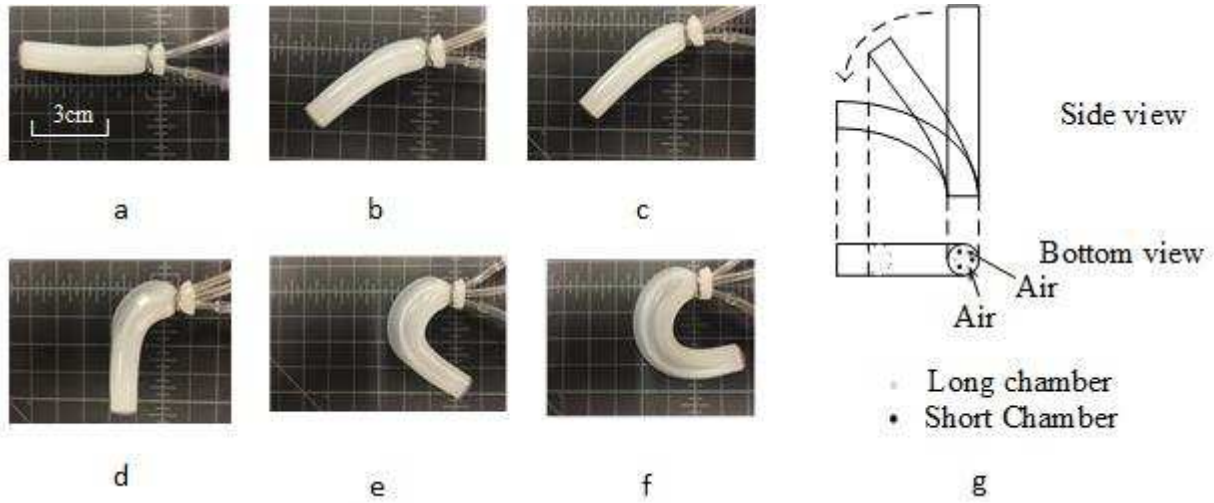

**Figure 1.3.** (a)-(f): Apply same air pressure in two chambers of the six-chamber robotic actuator; (g) schematic of applying same air pressure in two chambers of the six-chamber robotic actuator

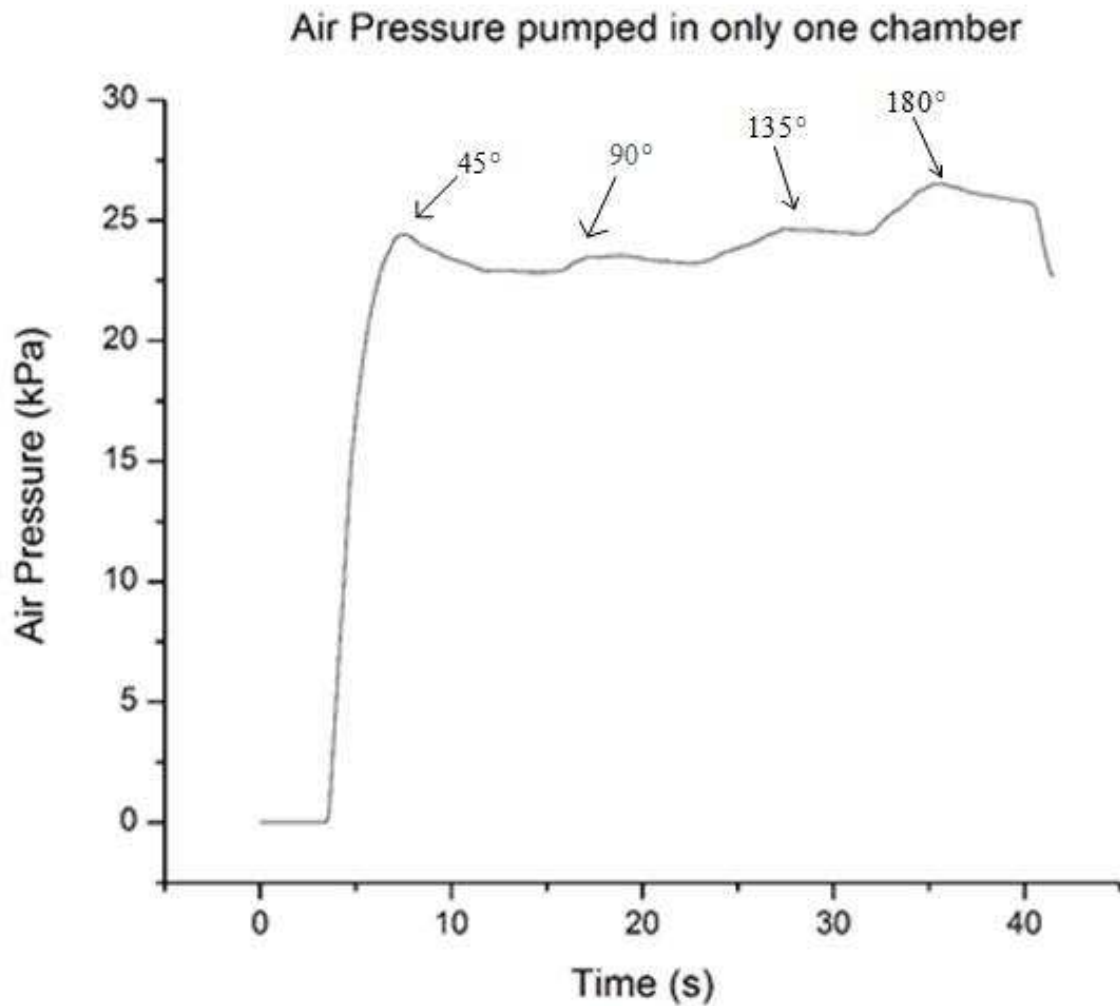

**Figure 1.4.** Pumping different air pressure into one long chamber of the six-chamber actuator

The stiffness of the six-chamber soft actuator can be much higher with applying a same air pressure in all six chambers. Six chambers located near each other would help reduce the risk of the ballooning effect to avoid bursting since the impact caused by applied air pressure can help every chamber squeeze each other.

In order to prove that the stiffness of the robotic actuator increases by increasing applied air pressure, one edge of the device is fixed and a weight is hanged at the middle of the robotic arm. With increasing the weight of the stuff, we measure the height that the robotic actuator drops, the stiffness of the device can be obtained according to Eq.1 [Figure 1.5(a)]. Table 1 shows that the stiffness of the six-chamber actuator is higher than the three-chamber one when applying a same air pressure in all chambers. Besides, improving applied air pressure also increase the mechanical stiffness of the actuator.

$$K = \frac{m_2g - m_1g}{(H_2 - H_1)} \text{ (Air pressure P1 pumped)} \quad \text{Eq. 1.1}$$

Where  $m_2$  and  $m_1$  are the mass of the weight,  $g$  is gravitational acceleration,  $H_2$  and  $H_1$  are the height difference between the final position and the initial position shown in Figure 1.5(c).

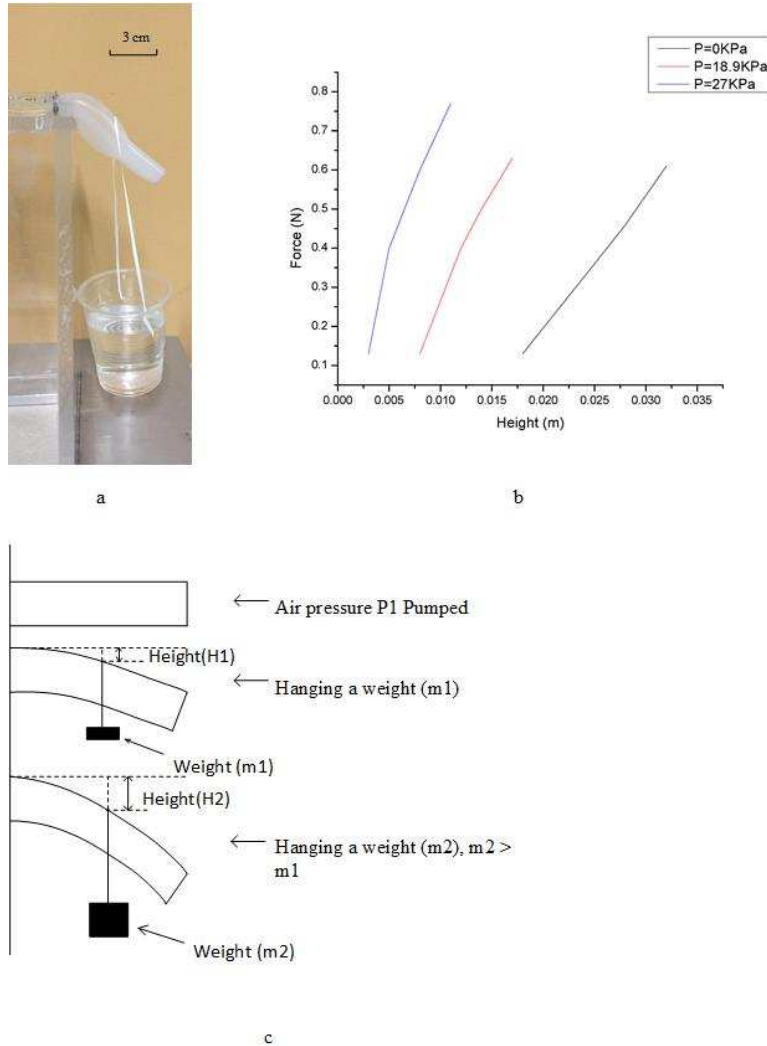

**Figure 1.5.** (a) Process of measuring the stiffness of the six-chamber robotic actuator with applying same air pressure in three long chambers; (b) the relationship of the force the six-chamber robotic actuator suffers from and the height the six-chamber robotic actuator drops under applying same air pressure in three long chambers; (c) schematic of measuring the stiffness of the six-chamber robotic actuator with applying same air pressure in six long chambers

**Table 1.1.** The corresponding stiffness of the three-chamber and six-chamber robotic actuator with increasing applied air pressure in all chambers

Inputted actuation air pressure (kPa)	0	18.9	27
Stiffness of the three-chamber robotic actuator(N/m)	32.86	51.11	71.25
Stiffness of the six-chamber robotic actuator(N/m)	33.95	70.34	96.25

The joint motion can take place via applying air pressure in chambers which are of different lengths (Figure 1.6). It's necessary since the joint motion can stabilize the structure of the device. Figure 6(a) shows one of joint motions the six-chamber actuator can achieve. The actuator owns excellent flexibility with a larger angular movement.



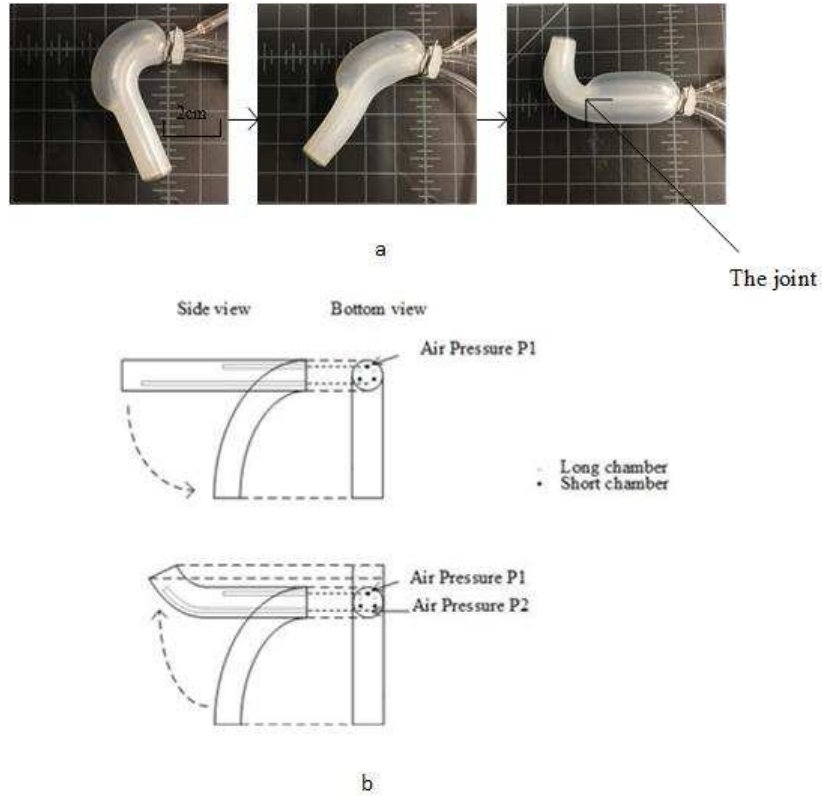

**Figure 1.6.** (a) The process of the six-chamber robotic actuator bending with applying air pressure into two farthest chambers in turn (b) schematic of the six-chamber robotic actuator bending with applying air pressure into two farthest chambers in turn

Various three-dimensional bending modes can be achieved when the air pressure is applied in different chambers of six-chamber actuator. Figure 1.7 shows one of process that the six-chamber robotic actuator rotates in three-dimensional space. Bending in three-dimensional space can improve the imaging area compared to in-plane bending.



a



b

**Figure 1.7.** (a) The process of the six-chamber robotic actuator bending with applying air pressure into two short chambers and one long chamber (Top view) (b) the process of the six-chamber robotic actuator bending with applying air pressure into two short chambers and one long chamber (cross-section view)

## Conclusions

Pneumatic actuation in soft robotics inspired by animals is often used in reality. A number of skin structures were designed after inspiration from nature and architecture. A highly elastomeric siloxane (Ecoflex) is used to build the soft actuator in our design. Applying air pressure in different chambers helps the actuator achieve different bending modes in two-dimensional or three-dimensional space. High stiffness is a significant requirement if the six-chamber soft robotic actuator needs to work as current robots with rigid manipulators. The stiffness of the six-chamber actuator increases when air pressure is applied into chambers.

## References

1. Daniela Rus, Michael T. Tolley. Design, fabrication and control of soft robots. *Nature* **521**,467-475(28 May 2015). doi:10.1038/nature14543
2. Marchese, Andrew D., Russ Tedrake, and Daniela Rus. "Dynamics and trajectory optimization for a soft spatial fluidic elastomer manipulator." *The International Journal of Robotics Research* (2015): 0278364915587926.
3. Richard, M., & Clavel, R. (2011). Concept of modular flexure-based mechanisms for ultra-high precision robot design. In *Proceedings of the 2nd International Symposium on Compliant Mechanisms* (No. EPFL-CONF-166032).
4. Yun, Yuan, and Yangmin Li. "Design and analysis of a novel 6-DOF redundant actuated parallel robot with compliant hinges for high precision positioning." *Nonlinear Dynamics* 61.4 (2010): 829-845.
5. Pérez-Arancibia, N. O., Ma, K. Y., Galloway, K. C., Greenberg, J. D., & Wood, R. J. (2011). First controlled vertical flight of a biologically inspired microrobot. *Bioinspiration & Biomimetics*, 6(3), 036009.
6. Albu-Schäffer, A., Eiberger, O., Grebenstein, M., Haddadin, S., Ott, C., Wimböck, T., ... & Hirzinger, G. (2008). Soft robotics. *Robotics & Automation Magazine, IEEE*, 15(3), 20-30.
7. Onal, C. D., & Rus, D. (2013). Autonomous undulatory serpentine locomotion utilizing body dynamics of a fluidic soft robot. *Bioinspiration & biomimetics*,8(2), 026003.
8. Mazzolai, B., Margheri, L., Cianchetti, M., Dario, P., & Laschi, C. (2012). Soft-robotic arm inspired by the octopus: II. From artificial requirements to innovative technological solutions. *Bioinspiration & biomimetics*, 7(2), 025005.
9. Marchese, A. D., Onal, C. D., & Rus, D. (2014). Autonomous soft robotic fish capable of escape maneuvers using fluidic elastomer actuators. *Soft Robotics*, 1(1), 75-87.
10. Park, Y.-L. *et al.* Design and control of a bio-inspired soft wearable robotic device for ankle-foot rehabilitation. *Bioinspir. Biomim.* **9**, 016007 (2014).
11. Mengüç, Y. *et al.* Wearable soft sensing suit for human gait measurement. *Inter. J. Robotics Res.* **33**, 1748–1764 (2014).
12. Lin, H. T., Leisk, G. G., & Trimmer, B. (2011). GoQBot: a caterpillar-inspired soft-bodied rolling robot. *Bioinspiration & biomimetics*, 6(2), 026007.
13. Walker, I. D., Dawson, D. M., Flash, T., Grasso, F. W., Hanlon, R. T., Hochner, B., ... & Zhang, Q. M. (2005, May). Continuum robot arms inspired by cephalopods. In *Defense and Security* (pp. 303-314). International Society for Optics and Photonics.

14. ROBOTICS, S. (2011). From the octopus to soft robots control: an octopus inspired behavior control architecture for soft robots. *Vie et milieu-life and enVironment*, 61(4), 211-217.
15. Calisti, M. *et al.* An octopus-bioinspired solution to movement and manipulation for soft robots. *Bioinspir. Biomim.* **6**, 036002 (2011).
16. Laschi, C., Cianchetti, M., Mazzolai, B., Margheri, L., Follador, M., & Dario, P. (2012). Soft robot arm inspired by the octopus. *Advanced Robotics*, 26(7), 709-727.
17. Shan, W., Lu, T. & Majidi, C. Soft-matter composites with electrically tunable elasticrigidity. *Smart Mater. Struct.* **22**, 085005 (2013).
18. Cheng, N. G., Gopinath, A., Wang, L., Iagnemma, K. & Hosoi, A. E. Thermally tunable, self-healing composites for soft robotic applications. *Macromol. Mater. Eng.* **299**, 1279–1284 (2014).
19. Lekakou, C., Elsayed, Y., Geng, T., & Saaj, C. M. (2015). Skins and Sleeves for Soft Robotics: Inspiration from Nature and Architecture. *Advanced Engineering Materials*, 17(8), 1180-1188.

## CHAPTER 2. MICROFLUIDIC IMAGING SYSTEM FOR ANALYZING NEMATODES LOCOMOTION

### Abstract

This article reports on a microfluidic imaging system for tracking nematodes *C. elegans* locomotion. The well-plate is placed at relatively higher position compared to the flow-diverting device. Liquid medium is pumped to infuse and fill the plastic tubings through the flow-diverting device, to create syphon effect. When the medium flow out of the plate into the flow-diverting device, 24 channels in the flow-diverting device made by PDMS (Polydimethylsiloxane) serve as imaging channels, where worms' shadows are imaged by the camera sitting below.

**Keywords:** *C.elegans*, microfluidics, shadow imaging, syphon effect

## Introduction

Researchers has used C.elegans as a tool to address biological questions because of its versatility in simple nervous system, and short life span [1, 2]. However, it is challenging to track nematodes locomotion due to their small and flexible bodies. Thus, there is a need for high-throughput imaging techniques that can be used to study such behaviors.

Because PDMS is transparent, images with high quality can be taken easily which perform behaviors of animals in microfluidic devices [3]. Besides, due to small size of channels, small amounts of liquid can be manipulated and it provides precise analysis of C. elegans [4]. Additionally, making microfluidic devices is relatively cheap since the technique of soft lithography is widely used in microfabrication more recently.

Taking images of nematodes locomotion is important for getting information from microfluidic devices. Researchers often used Traditional microscopes to observe nematodes in microfluidic devices [5,6,7]. Well-developed microfluidic devices are able to be directly put into the imaging system. However, traditional large imaging systems cannot hold the on-chip microfluidic devices well. In order to solve this issue, much researchers have paid efforts to develop compact imaging systems that microfluidic devices can be integrated with the imaging system. The imaging system can be divided into two parts. First, the imaging system are developed based on lens imaging. They are designed to be compatible with microfluidic devices [8,9,10]. Second, lens-less imaging systems are developed in order to make the whole system more compact since no more lens are added [11,12,13]. We use lens-less shadow imaging technique to record nematodes C. elegans locomotion in micro channels. The structure of whole system is simple to be built.

## Design and Fabrication

The whole microfluidic system includes two major components: a flow-diverting device being used as a carrier of *C. elegans* and a camera [Figure 2.1]. In order to let the medium with worms flow spontaneously in the flow-diverting device, we design an integrating syphon-based suction mechanism [Figure 2.2]. The process includes two modes: initialization mode and pumping mode. In initialization mode, liquid medium is pumped to infuse and fill the plastic tubings through the flow-diverting device on the table, to create syphon effect. In pumping mode, the medium (containing worms) are automatically flowed out of the plates into the diverting device. Now, the 24 channels in the diverting device serve as imaging channels.

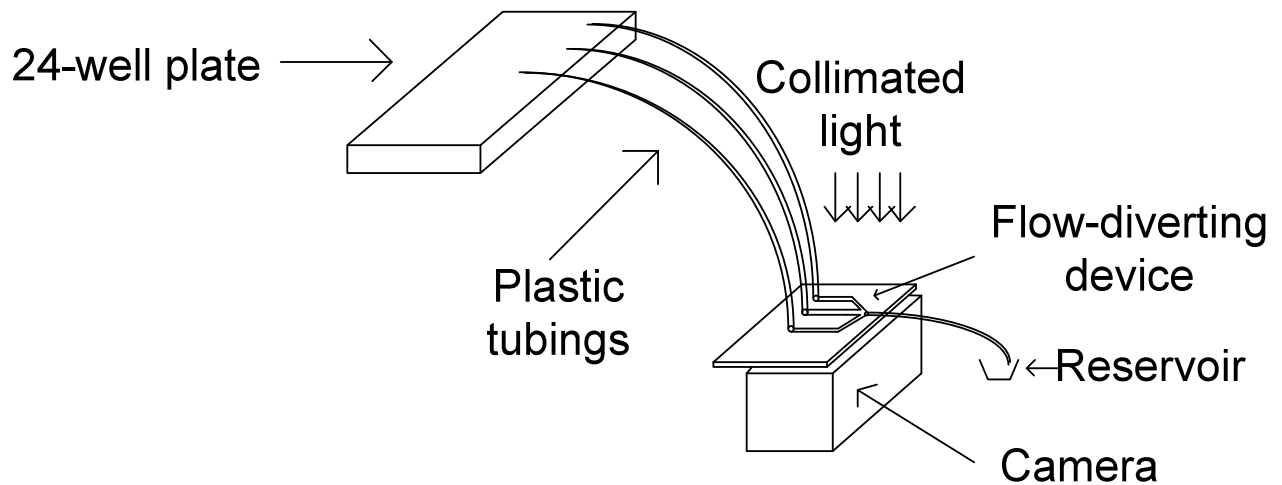

**Figure 2.1.** Schematic of syphon-based microfluidic imaging system



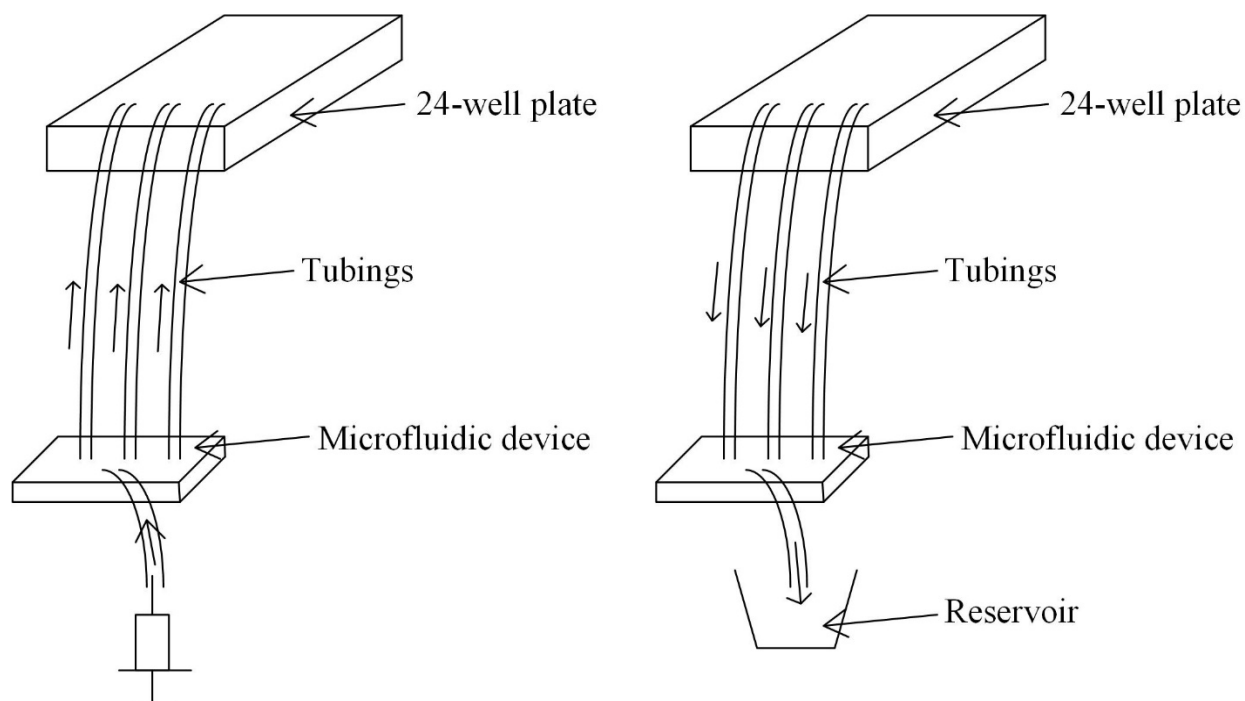

**Figure 2.2.** The process of Syphon-based suction mechanism.

The material of flow-diverting device is PDMS (Polydimethylsiloxane). It contains 24-channels and the width each channel is 0.5 mm so that nematodes can flow through it successfully. The flow-diverting device has one port on one end, and 24 ports on the other end [Figure 2.2].

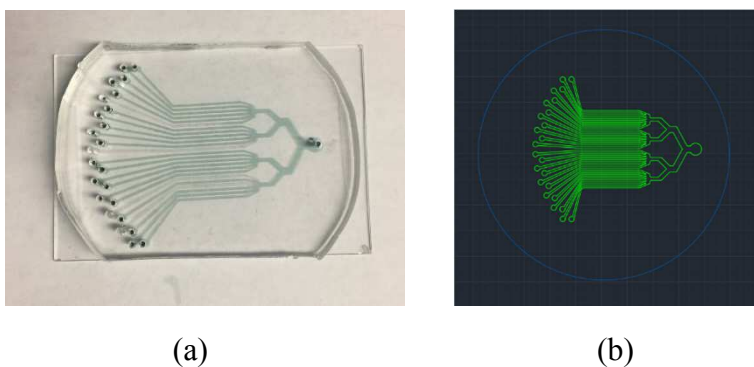

**Figure 2.3.** (a) The flow-diverting device made in PDMS (b) The structure of 24-channel flow-diverting device

To fabricate the flow-diverting device, we use SU-8 100 photoresist. In order to let nematodes flow successfully through the device, each channel's thickness is 100  $\mu\text{m}$ .

The shadow imaging system mainly consists of two major components: A light source is placed on the top of the device and a camera is affixed below [Figure 2.3].

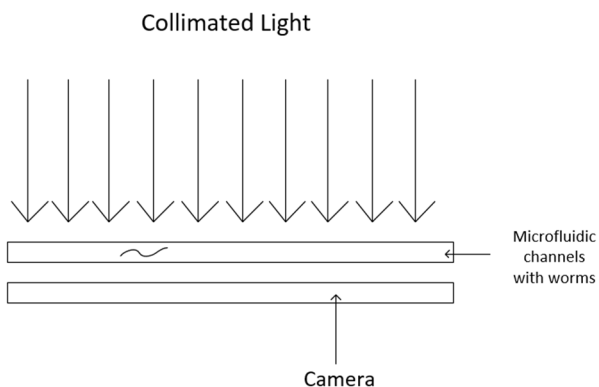

We used Raspberry-pi camera due to its small size and relatively low price. Besides, its resolution is  $3280 \times 2464$  pixels, which is enough to record images with high quality. However, in order to successfully record nematodes' locomotion, a lens is fixed on the camera so that when the camera is put closer to the flow-diverting device, it can still take high-quality image [Figure 2.4]. Only if camera is close enough to the device, nematodes locomotion can be recorded since each nematode's length is only around  $300 \mu\text{m}$ .



(a)

(b)

**Figure 1.5.** (a) Front view of Shadow imaging system (b) top view of shadow imaging system

## Result and Discussion

By applying shadow imaging technique, the image quality is good and nematodes' movement can be recorded successfully [Figure 2.4].



**Figure 2.6.** Recorded nematodes in one channel by shadow imaging

Flow rate is calculated. The volume of each well is around  $4.58\text{cm}^3$  and the time lasts 8 minutes and 40 seconds. The average flow rate is  $0.0088\text{cc/s}$ . In this condition, the height difference between 24-well plate and the flow-diverting device is 13 cm. By controlling the height difference between 24-well plate and the flow-diverting device, we can control the flow rate. While we increase height difference between 24-well plate and the flow-diverting device, the flow rate is larger.

## Conclusions

*C. elegans* has been widely used as a genetic tool to address some fundamental biological questions. With microfluidic devices made by transparent materials (PDMS), shadow imaging techniques can be used properly to record nematodes' locomotion. Raspberry pi camera is one of perfect options due to its low price, high resolution and small size. Pumping-mode of our process only lasts 20 minutes, which dramatically increases the efficiency compare to some traditional techniques.

## References

1. Fire, Andrew, et al. "Potent and specific genetic interference by double-stranded RNA in *Caenorhabditis elegans*." *nature* 391.6669 (1998): 806-811.
2. Bargmann, Cornelia I. "Neurobiology of the *Caenorhabditis elegans* genome." *Science* 282.5396 (1998): 2028-2033.
3. Ben-Yakar, Adela, Nikos Chronis, and Hang Lu. "Microfluidics for the analysis of behavior, nerve regeneration, and neural cell biology in *C. elegans*." *Current opinion in neurobiology* 19.5 (2009): 561-567.
4. Kovarik, Michelle L., et al. "Micro total analysis systems: fundamental advances and applications in the laboratory, clinic, and field." *Analytical chemistry* 85.2 (2013): 451.
5. Wu, Jigang, Guoan Zheng, and Lap Man Lee. "Optical imaging techniques in microfluidics and their applications." *Lab on a Chip* 12.19 (2012): 3566-3575.
6. Wang, Zuankai, et al. "Microfluidic CD4+ T-cell counting device using chemiluminescence-based detection." *Analytical chemistry* 82.1 (2009): 36-40.
7. Fan, Xudong, and Ian M. White. "Optofluidic microsystems for chemical and biological analysis." *Nature photonics* 5.10 (2011): 591-597.
8. Erickson, David, and Dongqing Li. "Integrated microfluidic devices." *Analytica chimica acta* 507.1 (2004): 11-26.
9. Gai, Hongwei, Yongjun Li, and Edward S. Yeung. "Optical detection systems on microfluidic chips." *Microfluidics*. Springer Berlin Heidelberg, 2011. 171-201.
10. Yu, Shuda, et al. "P-28: Contrast Enhancement for Imaging System using Electrically Tunable Liquid Crystal Lens." *SID Symposium Digest of Technical Papers*. Vol. 46. No. 1. 2015.
11. Sobieranski, Antonio C., et al. "Portable lensless wide-field microscopy imaging platform based on digital inline holography and multi-frame pixel super-resolution." *Light: Science & Applications* 4.10 (2015): e346.
12. Moon, SangJun, et al. "Integrating microfluidics and lensless imaging for point-of-care testing." *Biosensors and Bioelectronics* 24.11 (2009): 3208-3214.
13. Cui, Xiquan, et al. "Lensless high-resolution on-chip optofluidic microscopes for *Caenorhabditis elegans* and cell imaging." *Proceedings of the National Academy of Sciences* 105.31 (2008): 10670-10675.

### CHAPTER 3 SUMMARY AND CONCLUSIONS

The major work presented in this thesis includes two parts. The first project is about designing a biomimetic soft actuator inspired by elephant trunk. The second project is about developing a microfluidic device to record nematodes' locomotion by shadow imaging technique.

For the biomimetic soft actuator's project, we fabricated the actuator using Ecoflex, which is even softer than PDMS. It provides the actuator good flexibility so that it can bend for large degree of freedom. By measuring stiffness, it proves that the soft actuator can be very stiff under large air pressure applied. Achieving multiple bending modes is another success since in the future, some practical application like setting an endoscope on the actuator might be considered because it can rotate freely.

For the nematodes' project, we use *C. elegans* as our tool because of its versatility in behavior, simple nervous system and short life cycle. A 24-channel microfluidic device is used as a flow-diverting device and compared to traditional analyzing process, our pumping-mode save a lot of time and nematodes. Shadow imaging technique is used to record nematodes movement. Compared to traditional lens-free shadow imaging technique, we used a Raspberry pi camera combined with two lens. The Raspberry pi camera offers higher resolution and its price is very low.

## CHAPTER 4 FUTURE WORK

For the first project, we will consider some practical applications used on the actuator. An endoscope or a camera chip might be considered since their small size and light weight. More bending modes may be observed if we distribute all chambers differently.

For the second project, it's hard now to accurately record all 24 channels at the same time. We will try different lens combined with our camera till that when we place the camera at a proper distance to the flow-diverting device, it can successfully record all 24 channels at the same time. Besides, Controlling the speed of fluids flowing is another important issue. Trying to change height difference between the well-plate and the flow-diverting device, or changing tubes which are used to connect the plate and the microfluidic device, is some good option.